

SW series

Digital Scale



SW series Digital Scale

FEATURES

- Battery Operation with Auto Power Feature
- Large LCD (H=1inch/25mm) Display
- lb/kg/oz Switchable
- Soft Touch Tack Switch
- Compact Design & Stainless Steel platter
- Zero, Net, Stable, Low Battery Indicators
- Function : On/Off, Zero, Tare, Unit
- NTEP Approval number : 99-002

SPECIFICATIONS

Model	SW - 1				
Capacity	lb	5 ×0.002lb	10×0.005 lb	20 ×0.01 lb	50 ×0.02 lb
	kg	2 ×0.001 kg	5×0.002 kg	10 ×0.005 kg	20 ×0.01 kg
	g	2000 ×1 g	5000 ×2 g	10000 ×5 g	20000 ×10 g
	oz	80 ×0.05 oz	160 ×0.1 oz	400 ×0.2 oz	800 ×0.5 oz
Display Digit	5 Digit LCD (1 inch)				
Display Designators	Stable, Zero, Net, Batt.				
Measurement Type	Load Cell				
Power Source	DC 9V (1.5V ×6EA)/ AC Adapter Option				
Power Consumption	0.25W				
Operating Time	Alkaline Dry Battery : 1000hr Mn Battery : 500hr				
Operating Temperature	-10°C ~ +40°C (14°F ~ +104°F)				
Platter Size(mm/inch)	230(W) × 190(D)/9.05(W) × 7.48(D)				
Dimensions(mm/inch)	260(W) × 287(D) × 137(H)/ 10.23(W) × 11.29(D) × 5.39(H)				
Product Weight	3.14kg/6.92lb				

OPTION

- Rear Display

DISPLAY ON THE REAR SIDE



Option

DIMENSIONS

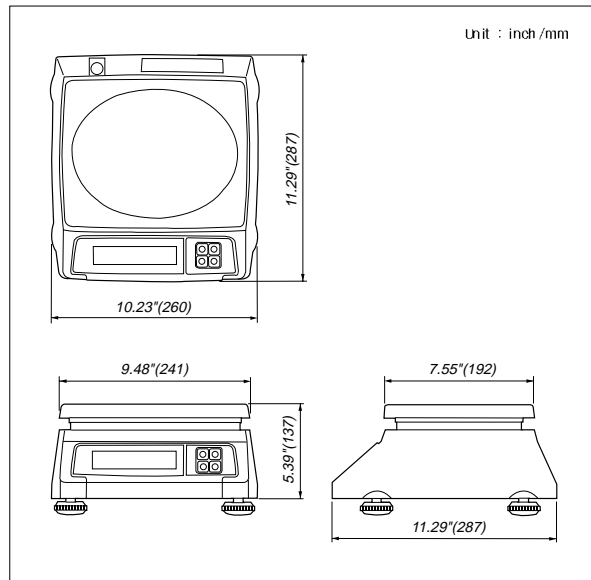

CAS USA Corporation

NJ OFFICE
99 Murray Hill Parkway
East Rutherford, NJ 07073
Tel: (201) 933-9002
Fax: (201) 933-9025

CA OFFICE
733 S. State College Blvd #98
Fullerton, CA 92831
Tel: (714) 870-1286
Fax: (714) 870-1167

<http://www.cas-usa.com>