

# DP-6200



## Versatile Indicator

Large, Easy-to-Read Display  
Over/Under Weighing  
Tiltable Indicator

## Large, Rugged Platform

Stainless Steel Housing  
Wide Capacity Range  
USDA Accepted

# DIGITAL SCALE

## DP-6200

### Versatile Indicator

### Large, Rugged Platform

#### Features

- ◆ Large LCD Display
- ◆ Over/Under Indicator
- ◆ Stainless Steel Platform
- ◆ Automatic Zero Setting Mechanism
- ◆ Initial Zero Setting Mechanism
- ◆ Preset or Push Button Tare
- ◆ Battery Operation
- ◆ Auto Shut-Off
- ◆ NEMA 4 Water Rating (when battery operated)
- ◆ Legal-for-Trade
- ◆ USDA Accepted
- ◆ Tilttable and Rotatable Indicator
- ◆ Push Button Keys
  - On, Off, Tare, Net/Gross, Clear, and LB/KG Unit Toggle
- ◆ LCD Indicators
  - Net/Gross, Stable, Tare, Center of Zero, Low Battery, & Over/Under

#### Options

- ◆ AC Adaptor
- ◆ RS-232C

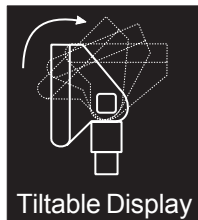

#### Applications

An excellent, easy-to-use, digital scale for general purpose weighing and accurate check-weighing. The DP-6200's large display makes it easy to read from any angle or distance.

#### Specifications

Model	DP-6200	
Accuracy Class	Class III 3000 Divisions	
Certificate of Conformance #	03-002	
Capacity and Division	Decimal Pound	Decimal Kilogram
	60 lb x 0.02 lb	30 kg x 0.01 kg
Capacity and Division	150 lb x 0.05 lb	60 kg x 0.02 kg
	300 lb x 0.1 lb	150 kg x 0.05 kg
Capacity and Division	Pound / Ounce	Continuous Ounce
	60 lb x 0.5 oz	960 oz x 0.5 oz
Capacity and Division	150 lb x 1 oz	2400 oz x 1 oz
	300 lb x 2 oz	4800 oz x 2 oz
Weighing System	Strain Gauge Load Cell	
Platform	13.8 x 19.7 (350 x 500); Stainless Steel	
Indicator	Liquid Crystal Display: 5 Digits plus indicators Character size: 0.9 x 0.5 (23 x 12)	
Power Supply	9 Volt DC; 6 "D" size batteries (not included)	
Battery Life	600 Hours of Continuous Use (alkaline batteries)	
Operating Temp.	23°F ~ 95°F (-5°C ~ 35°C)	
Shipping Weight	37 lb (17 kg)	

All weights and dimensions are approximate. Dimensions are given in inches and (millimeters).

#### Dimensions

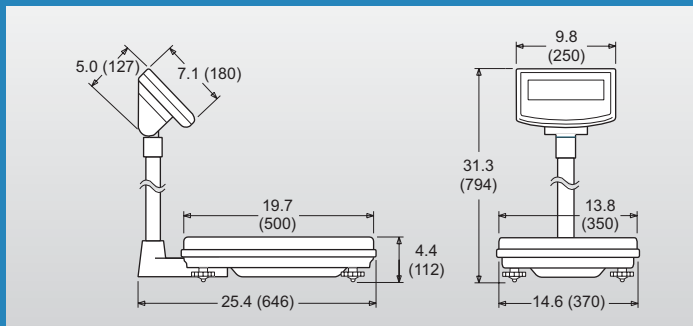

#### Indicator \ Keypad

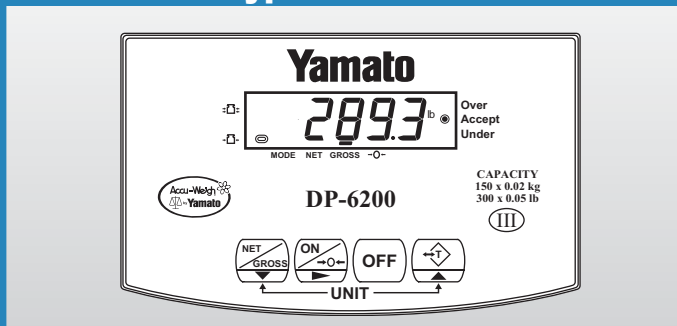

# Yamato

www.YamatoCorp.com

Yamato Corporation  
P.O. Box 15070  
Colorado Springs, CO 80935-5070  
U.S.A.  
Tel (719) 591-1500  
Fax (719) 591-1045

Yamato Tech Corporation  
#112-19425 Langley By-Pass  
Surrey, B.C. V3S 6K1  
Canada  
Tel (604) 533-2338  
Fax (604) 533-0827